

Trail Signing - General Sign Types

section: n.t.s.

Type A Sign: Motorist Sign/Gateway Kiosk

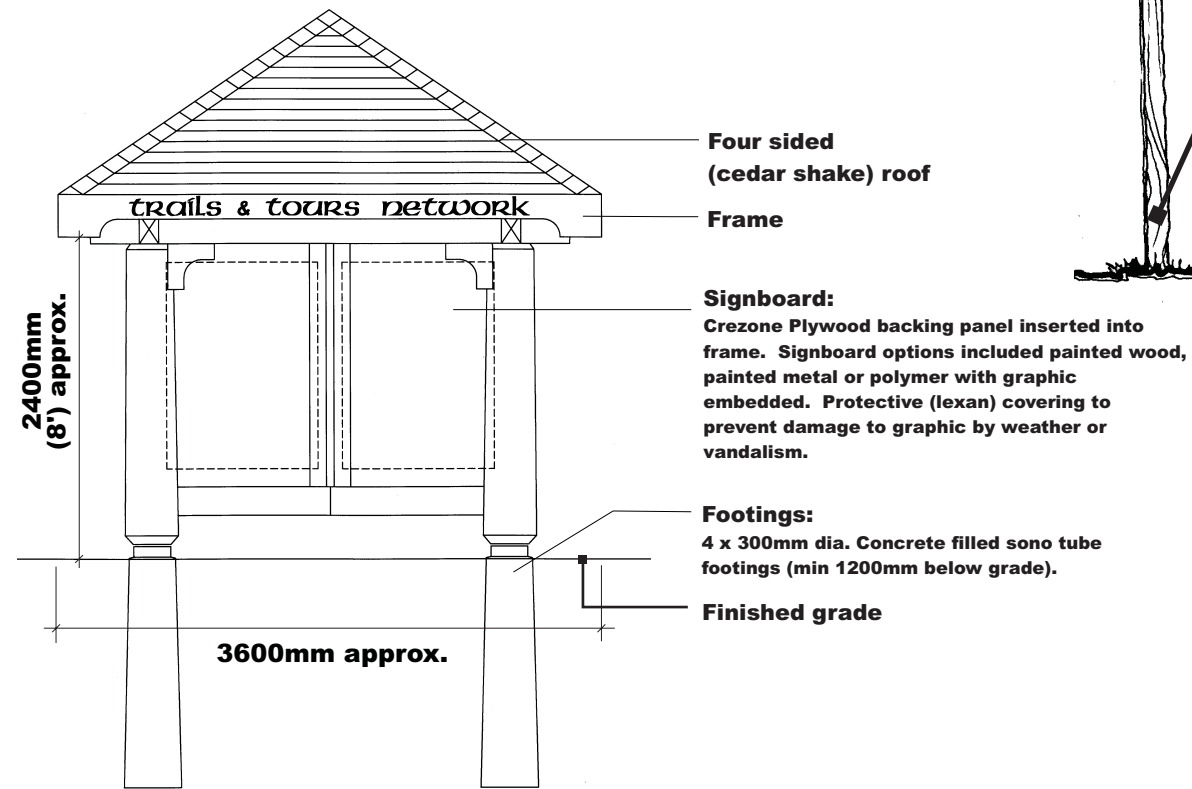

Type C Sign: Directional Sign

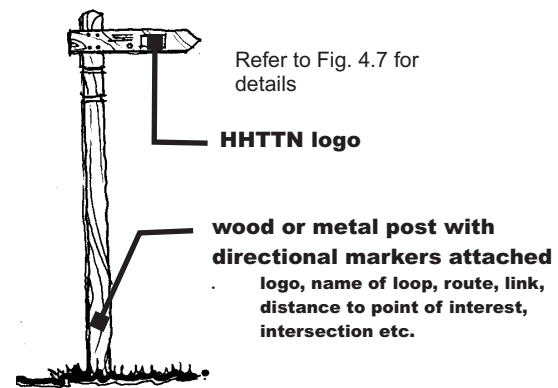

Refer to Figs 4.3 and 4.4 for details

Type B Sign: Trail Head/Trail Node Kiosk

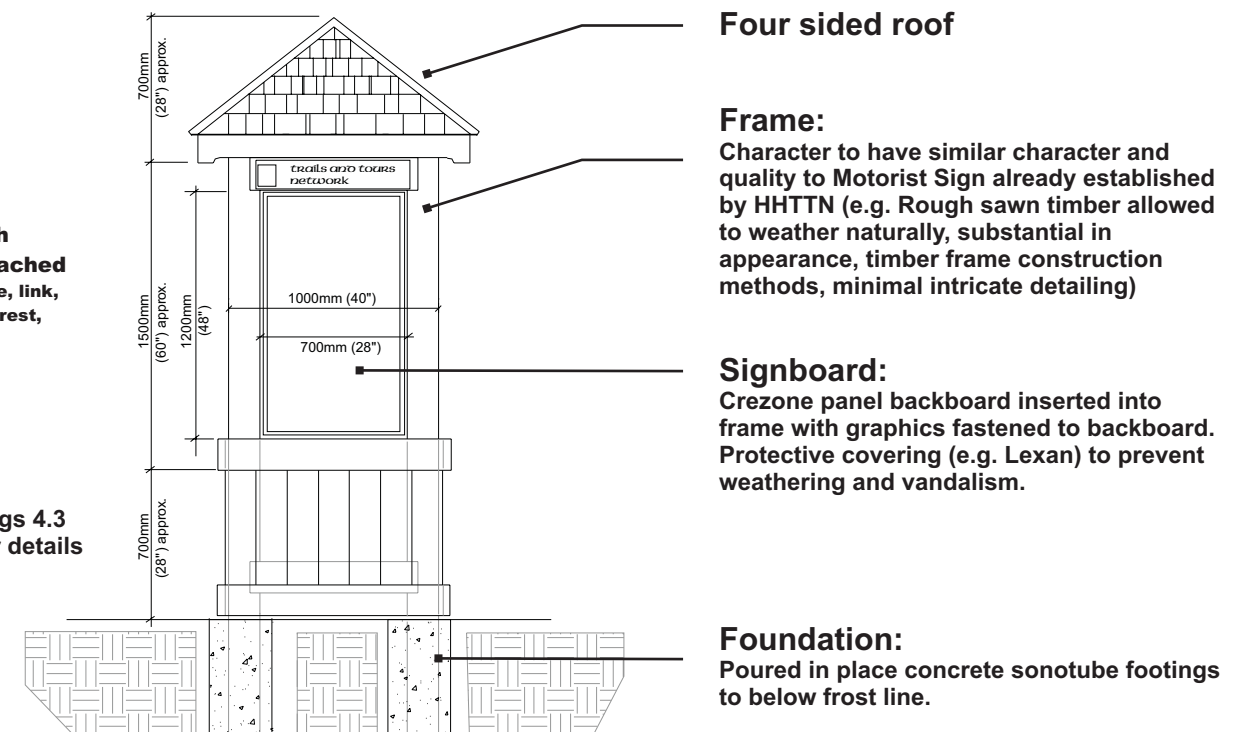

Type E Sign: Minor Trail Head Sign/Interpretive Sign

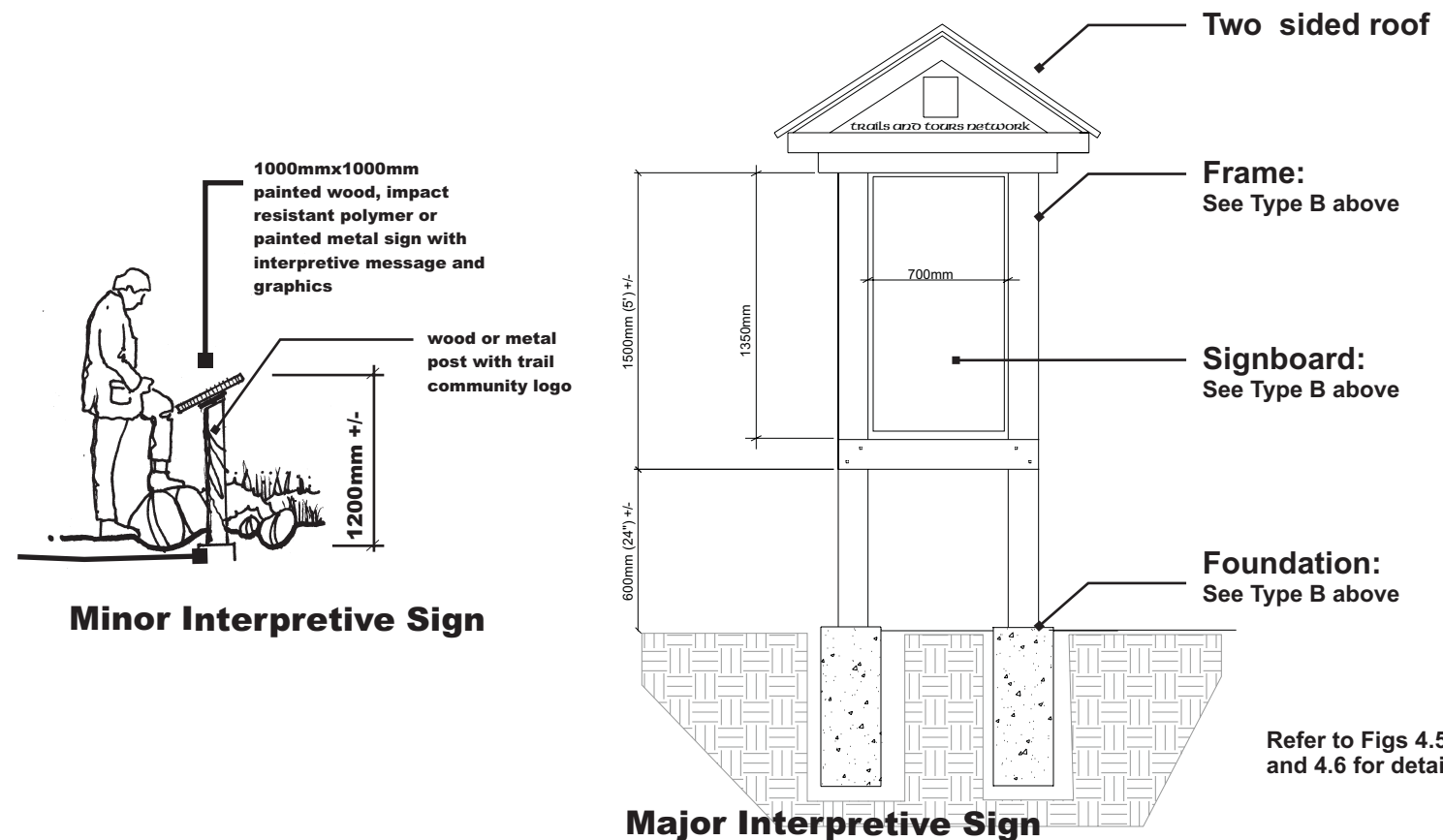

Minor Interpretive Sign

Major Interpretive Sign

Notes:

1. These sketches are intended to convey the hierarchy of signs and design elements, not necessarily the design. It is suggested that a signing "system" be developed that uses consistent materials, graphics and details, so that all of the signs appear to be from the same "family".
 2. It is suggested that all traffic control signs (regulatory) associated with all off-road trails conform to standards in the "Manual of Uniform Traffic Control Devices for Canada: Sign Pattern Manual", developed by the Transportation Association of Canada (TAC).
- Note:** In similar projects, off road signing sizes have been reduced to approximately 75% of the required sizing for on-road signing.
3. Any on-road bikeway signing and pavement marking must conform to the standards depicted in the Bikeway Traffic Control Guidelines for Canada, 1999.
 4. For roadside signage refer to text under "TOPS" signage (Transportation Association of Canada www.tac-atc.ca).

Type D Sign: Trail Marker

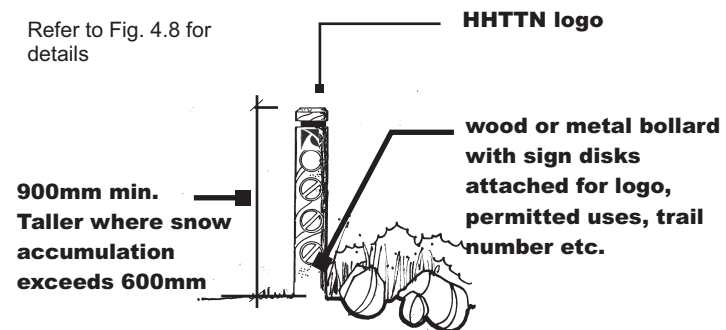

Fig 4.1

General Sign Types
Marshall Macklin Monaghan
CONSULTING ENGINEERS • ARCHITECTS • PLANNERS
ESG INTERNATIONAL

Trail Development Template
Haliburton Highlands Trails and Tours Network

